



## User Guide

# Milliflex Oasis<sup>®</sup> pump for the EZ-Fit<sup>®</sup> filtration unit



The life science business of Merck KGaA,  
Darmstadt, Germany operates as  
MilliporeSigma in the US and Canada.

## Table of Contents

<b>Introduction</b>	<b>3</b>	<b>5. Performance verification</b>	<b>17</b>
<b>1. Components</b>	<b>4</b>	<b>6. Use of multiple pumps</b>	<b>18</b>
1.1 Required items	4	6.1 Material needed	18
1.2 Description of items	5	6.1.1 Two pumps connected	18
1.3 Touch switch	6	6.1.2 Three pumps connected	18
<b>2. Hardware installation</b>	<b>7</b>	6.2 Installation	18
<b>3. Testing</b>	<b>9</b>	<b>7. System specifications</b>	<b>20</b>
3.1 Filtration units	9	<b>8. Ordering information</b>	<b>21</b>
3.2 Media plates	9	<b>9. Troubleshooting</b>	<b>23</b>
3.3 Testing	9	<b>10. Operator &amp; equipment safety instructions</b>	<b>23</b>
3.4 Waste	10	<b>11. Technical assistance</b>	<b>23</b>
<b>4. Cleaning &amp; maintenance</b>	<b>11</b>		
4.1 Cleaning & maintenance table	11		
4.2 Surface sanitizers and internal flow sanitizers table	11		
4.3 Filtration head cleaning	12		
4.4 Pump surface cleaning	12		
4.5 Pump rinsing	12		
4.6 Filtration head external gasket cleaning	12		
4.7 Pump internal flow sanitization	13		
4.8 Filtration head complete cleaning	14		
4.9 Filtration head gaskets and check valve (spare parts) replacement	15		
4.10 Sanitization kit gaskets and valve (spare parts) replacement	16		

## Notice

The information provided in this document (or any other literature) is subject to change without prior notice and shall not constitute a commitment of Merck KGaA, Darmstadt, Germany or any of its Affiliates. Merck KGaA, Darmstadt, Germany or any of its Affiliates expressly decline all warranties and shall not assume any responsibility for any errors that may appear in this document. This manual is believed to be complete and accurate at the time of publication. In no event shall Merck KGaA, Darmstadt, Germany or any of its Affiliates be liable for all damages (including but not limited to incidental or consequential damages) in connection with, or arising from, the use of this document or associated literature.

## Introduction

The Milliflex Oasis® pump for the EZ-Fit® filtration unit is a solution for the microbial testing of aqueous fluids.

The system is composed of the Milliflex Oasis® pump, the EZ-Fit® filtration unit and culture media. Please refer to the ordering information section for details on the different items.

### **EZ-Fit® filtration unit:**

The EZ-Fit® filtration unit is a disposable filtration device for bioburden testing of liquid samples including water, in-process samples, and final products.

The EZ-Fit® filtration units have been designed to ensure optimal microbial recovery. The sterilized, disposable filtration devices for bioburden testing streamline your workflow, save time and give you highly reliable microbial enumeration results. The blue and pink drain support and the funnel-to-base assembly have been optimized so that the membrane remains perfectly flat after the sample filtration so that when transferred to the culture medium, the whole filtration surface of the membrane is in perfect contact with the culture media. The shape of the funnel and the hydrophobic material minimize sample residue ensuring that the complete sample volume reaches the membrane surface. The innovative funnel assembly design prevents any leaks or sample by-pass of the membrane, meaning that the whole sample volume is filtered. EZ-Fit® filtration units conform to international standards (EP/USP) and comply with water testing regulations.

# 1. Components

## 1.1 Required items

**Three hardware item numbers are necessary to run the system:**

1. Milliflex Oasis® pump for EZ-Fit® filtration unit (item MMSYSTEZ1)
2. Milliflex Oasis® power supply for one to three filtration pumps, specific to defined regions:
  - Australia: item MMPWRSPAU
  - Brazil: item MMPWRSPBR
  - China: item MMPWRSPCN
  - Denmark: item MMPWRSPDK
  - Europe: item MMPWRSPEU
  - Switzerland: item MMPWRSPSZ
  - India: item MMPWRSPIN
  - UK: item MMPWRSPUK
  - Japan: item MMPWRSPJP
  - USA: item MMPWRSPUS
  - South Africa: item MMPWRSPZA
3. Milliflex Oasis® internal flow sanitization kit (item MMSANKIT1)

Optional: For higher throughput capability, it is possible to **connect two or three pumps** together without additional power supplies. In this case, the Milliflex Oasis® electrical cable for connecting two pumps (item MMCABLEMM) is required per additional pump.

Consumables: please refer to the ordering information section for details on the different items.

1. Filtration units
2. Culture media
3. Consumables for the Milliflex Oasis® internal flow sanitization kit

## 1.2 Item description

### The Milliflex Oasis® pump for EZ-Fit® filtration unit package (item MMSYSTEZ1) contains

1. Pump body
2. Two filtration heads with their covers
3. Tubing for discarding the liquids
4. Accessory kit
5. Spare parts kit



Figure 1: Milliflex Oasis® pump for EZ-Fit® filtration unit (MMSYSTEZ1) package components

### The Milliflex Oasis® power supply package contains

1. Power supply
2. Power cable (region specific)
3. Two rubber fasteners



Figure 2: Milliflex Oasis® power supply package components

### The Milliflex Oasis® internal flow sanitization kit (item MMSANKIT1) package contains:

1. Stainless steel sanitization kit with plug and gasket removal tool
2. Vacuum gauge

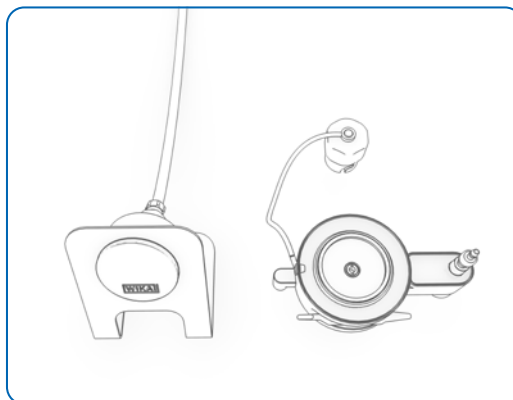


Figure 3: Milliflex Oasis® internal flow sanitization kit package components

### The EZ-Fit® filtration unit package contains 48 units.

**Culture media:** please refer to the ordering information section to select your preferred media.

### The Milliflex Oasis® consumable for internal flow sanitization kit (item MMSANSYFU) package contains:

1. Twenty-four plastic syringes for dispensing the sanitizer
2. Twenty-four funnel assemblies for rinsing with purified water

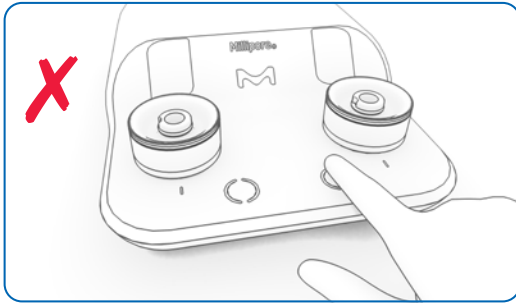
## 1.3 Touch switch

Color	Meaning
White	Steady: pump is ready for next handling step Blinking: membrane dry out on-going
Blue	Vacuum on
Green	The sanitization kit is ready to use
Red	No filtration head or filtration head is not locked
Orange	Blinking: synchronizing multiple pumps, wait
Off	No tension or standby

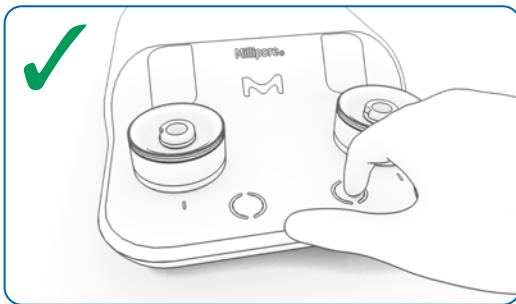
The switch is touch-sensitive. Use your fingertip to activate it.

Touch the center of the switch without touching the outer ring.

When the Milliflex Oasis® pump is in standby mode, it can be reactivated by touching the space between the two switches.



**Figure 4: INCORRECT**—no activation if the finger touches the outer ring



**Figure 5: CORRECT** finger position to start or stop the pump

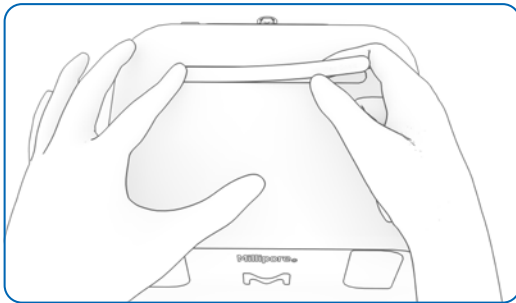
**Note: If unused for thirty minutes, the pump switches off. Touch the switch once to power up.**

## 2. Hardware installation

The pump must be installed on a horizontal surface. Please make sure that your working area is level to ensure good sample volume readings.

- Take the pump body, pump heads and tubing out of the package with care
- Take out the accessory bag and spare part bag

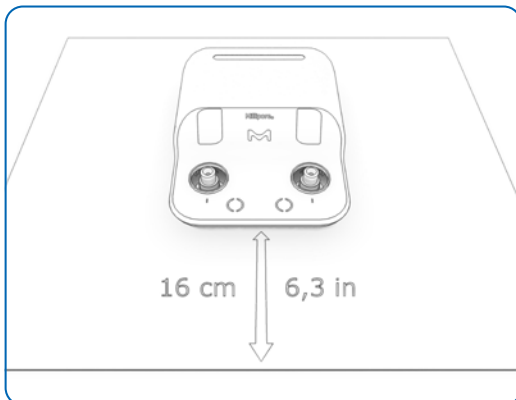
Optional: the accessory bag contains four stickers; select your preferred sticker and stick it carefully into the specific groove on the pump.



**Figure 6: Pump sticker set up**

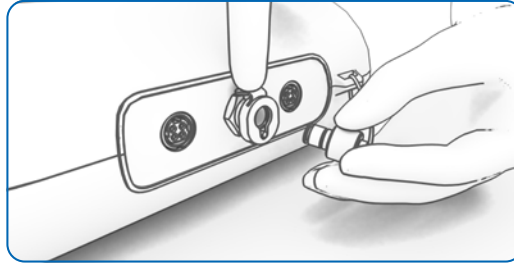
- Clean the exterior of the pump and the tubing using a wipe moistened with a surface sanitizer listed in the cleaning & maintenance section
- Place the pump in the working area

Under a horizontal laminar flow hood (LFH), the front of the pump should be placed at least at 160 mm (6.3 in.) from the front edge of the LFH (see picture).



**Figure 7: The front of the pump should be placed at least at 160 mm (6.3 in.) from the front edge of a horizontal LFH**

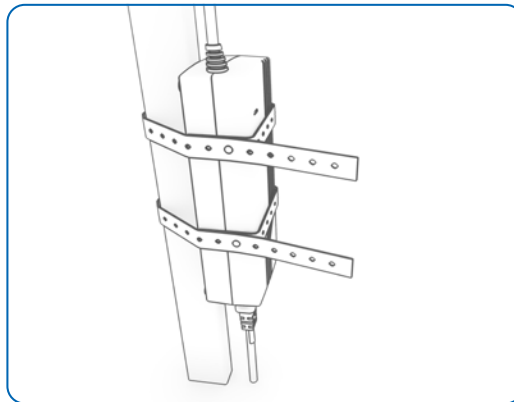
- On the back of the pump, press the metal latch and remove the white plug, then connect the tubing



**Figure 8: The metal latch must be pressed to remove the white plug**

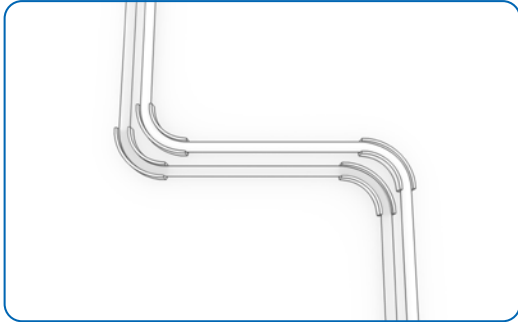
- Place the other end of the tubing in a liquid waste container
- Take out the power supply out of its package
- Sanitize the power supply in the same way as the pump
- Plug the DC power cord to one power port situated at the back of the pump. Push the connectors into the power port until a click is heard
- Connect the free power cord to the power supply
- Connect the other end of the power cord to a properly grounded power outlet

Optional: attach the power supply outside the working area with the two rubber fasteners.



**Figure 9: The power supply can be attached outside the working area with the rubbers fasteners**

Optional: to arrange the tubing and electrical cable in your working area, use the Milliflex Oasis® guides for electrical cable and tubing (item MMTUGUIDE).



**Figure 10: Use of Milliflex Oasis® guides for electrical cable and tubing (item MMTUGUIDE)**

- Sanitize the internal flow of the pump referring to the cleaning & maintenance section
- Once the internal flow path sanitization has been performed, take the two pump heads out of their package and remove the yellow covers

- Clean the pump heads using a wipe moistened with a surface sanitizer listed in the cleaning & maintenance section
- Install the pump heads on the pump body
- Lock the pump heads by turning clockwise until the sign on the head is aligned with the one on the pump body



**Figure 11: The sign on a locked head is aligned with the one on the pump body**

The pump is ready for testing.



## 3. Testing

The following components are needed before starting your sample processing:

- Milliflex Oasis® pump for EZ-Fit® filtration unit installed following the installation section
- EZ-Fit® filtration units
- Culture media
- Samples to test

Ensure that the internal pump flow was sanitized according to the cleaning & maintenance section.

- Clean the exterior of the pump using a wipe moistened with a surface sanitizer listed in the cleaning & maintenance section

### 3.1 Filtration units

Different types of filtration units are available (see ordering information section)

**Note: for testing samples with antimicrobial activity, select filtration units with low binding Durapore® membrane.**

**Note: Isopropyl myristate (IPM) is not chemically compatible, therefore sample containing IPM should not be used.**

- Open a box of filtration units and remove the desired numbers of bags or filtration units
- Repeat the operation if more than one box of filtration units is needed.
- Clean each bag or each unit using a wipe moistened with a surface sanitizer

### 3.2 Media plates

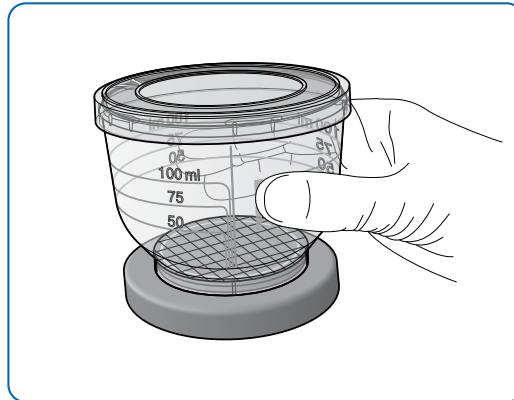
Follow the instructions of use for your selected culture media

### 3.3 Testing

When the pump is on standby mode, the switch is not lit up. To power up the Milliflex Oasis® pump, touch the front of the pump between the two switches with your fingertip.

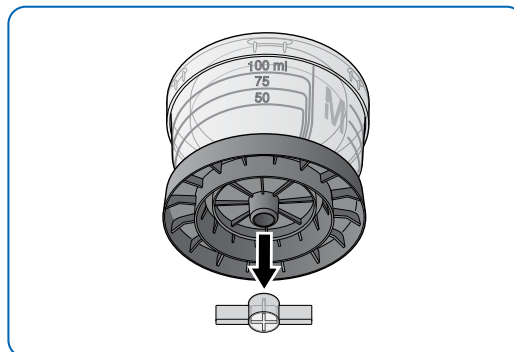
**Note: If starting a filtration without a filtration unit placed on the filtration head, you will hear a whistle noise, this is due to a check valve to be found in each pump head and is perfectly normal. If the pump is started after having placed a filtration unit on the pump head, this noise will not be heard.**

- Remove the device from the packaging by grasping the funnel



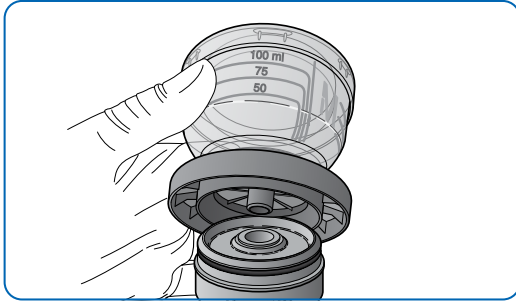
**Figure 12: Removing the unit from its packaging**

- Remove the plug from the bottom of the base (blue unit bulk packaging versions only)



**Figure 13: Removing the plug from the unit (blue unit bulk packaging versions only)**

- Place the EZ-Fit® filtration unit on the pump head

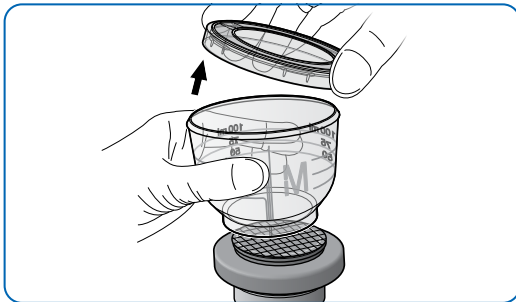


**Figure 14: Filtration unit placement on the pump head**

- Remove the funnel's cover and pour the sample into the unit
- Place the cover back in place
- Touch the switch to start the filtration

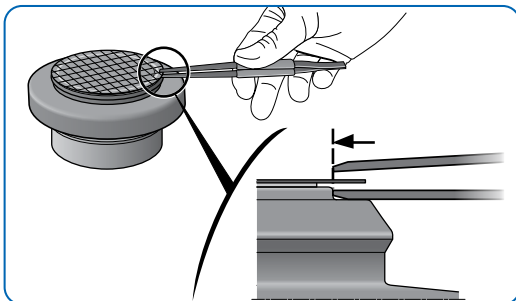
**Note: touch the switch three times within one second to launch the filtration on two filtration heads simultaneously.**

- Open a culture media plate.
- When the liquid is totally filtered, touch the switch once more to stop the filtration
- After a few seconds, the pump stops, and the switch light stops blinking then remove the cover and slightly pinch the funnel and remove it as shown here:



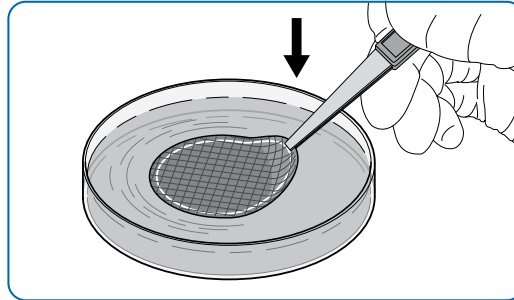
**Figure 15: Funnel removal**

- Remove the membrane using forceps.



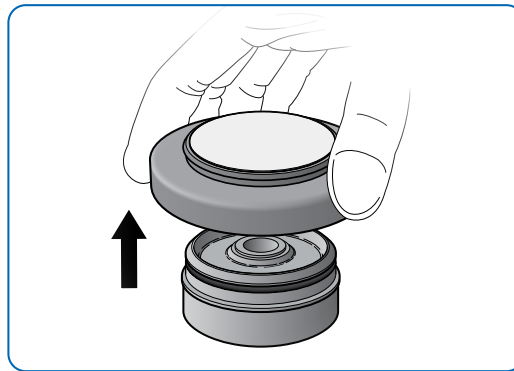
**Figure 16: Membrane removal**

- Place the membrane onto the culture media plate, close the plate, it is ready for incubation



**Figure 17: Membrane transfer onto culture media**

- Remove the base from the filtration head as shown here:



**Figure 18: Filtration unit base removal**

**Note: If some filtered liquid remains in the pump head, it is possible to remove it with a dry wipe. Regardless of the amount of liquid, it does not impact the test results.**

### 3.4 Waste

After usage, the funnels can be stacked to reduce waste volume.

Please refer to the waste management document available on our website to recycle the materials.

## 4. Cleaning & Maintenance

### 4.1 Cleaning & Maintenance table

Component	Action	First installation	Before each testing shift	After each testing shift	Monthly	Yearly
Filtration head	Cleaning	X	X	X		
Pump	Surface cleaning	X	X	X		
Pump	Internal flow sanitization	X			X	
Pump	Rinsing			If testing non-water samples		
Filtration head	External gasket cleaning			If testing non-water samples		
Filtration head	Complete cleaning				X	
Filtration head	Spare parts replacement					X
Sanitization kit	Spare parts replacement					X

**Note: Even if not mandatory, the filtration head including its components can be autoclaved at 121 °C for 15 minutes or at 134 °C for 5 minutes.**

### 4.2 Surface sanitizers and internal flow sanitizers tables

Surface sanitizer tested: Active ingredients	Suppliers	Dilution
Ethanol (N°CAS 64-17-5 : 226 mg/g) Chlorhexidine Digluconate (N°CAS 18472-51-0 : 0.64 mg/g) Didecylidimethylammonium chloride (N°CAS 7173-51-5 : 0.53 mg/g), Excipients.	Consult our local technical support	Ready to use
Propan-2-ol (70%), deionised water solution (30%)	Consult our local technical support	Ready to use
Ethanol (70%)	N/A	Ready to use
Quaternary ammonium: Benzalkonium chloride (between 0.25–0.5%) Poly (hexamethylene biguanide) hydrochloride (between 0.1–0.25%)	Consult our local technical support	Ready to use
Sodium Hypochlorite (2.6% active chloride)	N/A	250 ppm
hydrogen peroxide (6%)	Consult our local technical support	Ready to use
Isopropyl alcohol (N°CAS 67-63-0 10%) Didecylidimethylammonium chloride (N°CAS 7173-51-5: 0.15936%)	Consult our local technical support	Ready to use
hydrogen peroxide (1%) and acetic acid (5.2%)	Consult our local technical support	Ready to use
Peracetic acid (0.08%), hydrogen peroxide (1%), and acetic acid (<10%)	Consult our local technical support	Ready to use
Quaternary ammonium: Ethanol<25%, Didecylidimethylammonium chloride <0.5% N-(3-aminopropyl)-N-dodecylpropane-1,3diamine <0.5%	Consult our local technical support	Ready to use
Phenolic Disinfectant: Biphenyl-2-ol (CAS No 90-43-7: 7.7%) chlorophene (CAS No 120-32-1: 7.7%)	Consult our local technical support	8 mL/L
Alkaline disinfectant: Potassium hydroxide (CAS 1310-58-3) Tetrasodium ethylenediaminetetraacetate (CAS 64-02-8)	Consult our local technical support	47 mL/L

Internal flow sanitizers: active ingredients	Suppliers	Dilution
Quaternary ammonium: Benzalkonium chloride (between 0.25–0.5%) Poly (hexamethylene biguanide) hydrochloride (between 0.1–0.25%)	Consult our local technical service	Ready to use
Sodium Hypochlorite (2.6% active chloride) hydrogen peroxide (6%)	N/A	250 ppm
Isopropyl alcohol (N°CAS 67-63-0 10%) Didecyltrimethylammonium chloride (N°CAS 7173-51-5: 0.15936%)	Consult our local technical support	Ready to use

**Note: Sanitizers containing acetic acid at 0.1% or higher should not be used for internal flow sanitization because of chemical incompatibility.**

### 4.3 Filtration head cleaning

Remove the filtration heads and clean them using a wipe moistened with a surface sanitizer listed in the cleaning & maintenance section, then put them back in place.

### 4.4 Pump surface cleaning

Clean the exterior of the pump, the tubing and the cable using a wipe moistened a surface sanitizer listed in the cleaning & maintenance section.

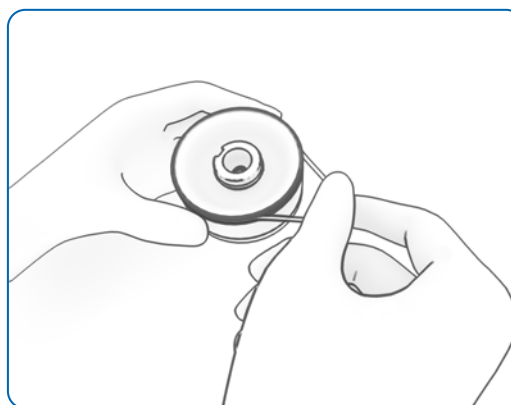
### 4.5 Pump rinsing

If samples other than water have been processed, filter 300 mL of purified water at the end of each day. This is recommended to ensure the functionality of internal parts.

Use either EZ-Fit® Filtration Unit or the internal flow sanitization kit with a sanitization funnel assembly to perform the rinsing.

### 4.6 Filtration head external gasket cleaning

- If testing non-water samples, remove the external gasket, then clean it including its groove



**Figure 19: External gasket removal**

## 4.7 Pump internal flow sanitization

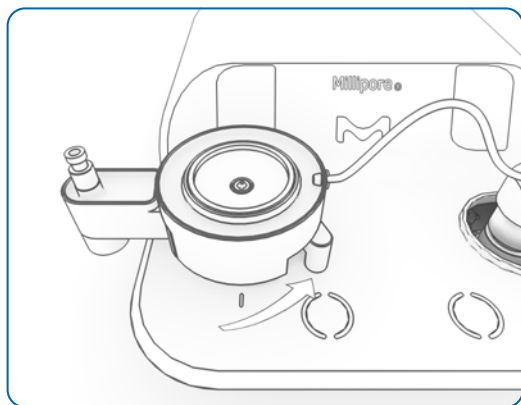
Material needed:

1. Sanitization kit (item MMSANKIT1)
2. Consumables for sanitization kit (item MMSANSYFU)
3. Sanitizer (see table)
4. Purified water

- Remove the pump heads
- Place a sanitization kit on one pump head support and lock it
- Lock the sanitization kit plug on the other support

Optional: For faster sanitization, it is possible to replace the plug by a second sanitization kit and sanitize the complete pump at once.

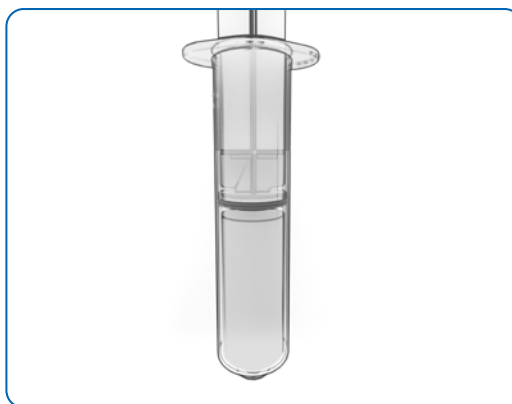
- Rotate the trigger counter clockwise, the switch turns green



**Figure 20: Trigger is rotated counter clockwise**

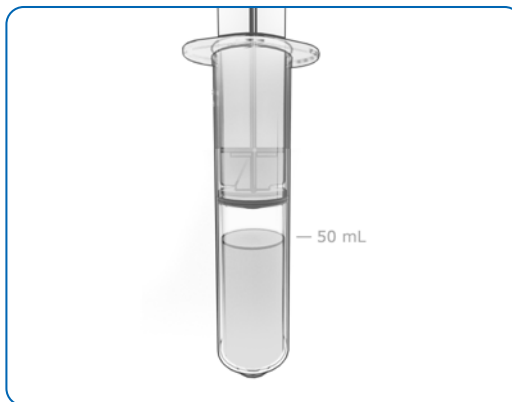
- Take one sanitization funnel assembly (sanitization kit consumable) and remove its support, then place the funnel on the kit
- Take a syringe (sanitization kit consumable) and remove its plunger
- Place and lock the syringe on the kit
- Pour 60 mL of sanitizer in the syringe
- Introduce the plunger into the syringe

**Note: An air pocket is visible over the liquid.**



**Figure 21: Visible air pocket over the liquid in the sanitization syringe**

- Push the plunger to bring the liquid level to the 50 mL level indicator



**Figure 22: Plunger pushed to bring the liquid to the 50 mL level indication of the sanitization syringe**

- Open the funnel lid
- Pour purified water up to the 250 mL indication level
- Put back the funnel lid
- Touch the switch to start the pump

**Note: the switch starts blinking for 15 minutes while the following operations occur:**

1. The plunger is partially pulled down and the sanitizer fills the pump internal flow.
2. About 10 mL of sanitizer remains into the syringe
3. The sanitizer remains in contact with the internal flow for 15 minutes

4. The plunger is pulled down completely
5. The water in the funnel is pulled to rinse the pump
6. The switch stops blinking
7. The pump switches off if not in use for thirty minutes

- When the light is steady or if the pump is switched off, repeat the operation for the second flow path
- Discard the sanitization kit consumables
- Remove the sanitization kit and clean it using a wipe moistened with a surface sanitizer listed in the cleaning & maintenance section

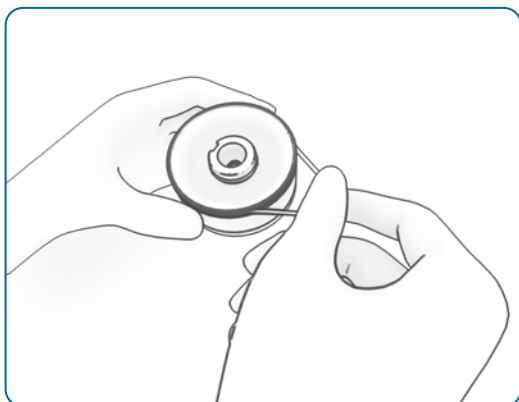
**Note: the sanitization kit can be autoclaved at 121 °C for 15 min or at 134 °C for 5 min.**

## 4.8 Filtration head complete cleaning

Materials:

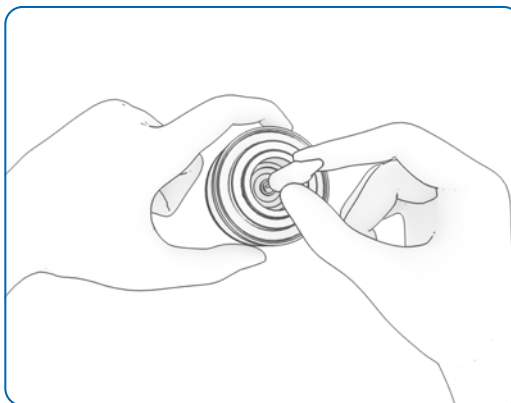
1. Pump head
2. Gasket removal tool (to be found in the pump spare part kit)
3. Sanitizer (see table)

- Remove the filtration head from the pump
- Remove the external silicone gasket at the exterior of the head

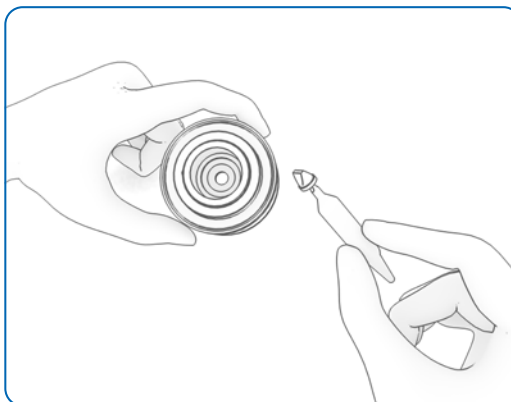


**Figure 23: External gasket removal**

- Remove the black check valve with the metal tool provided in the gasket kit



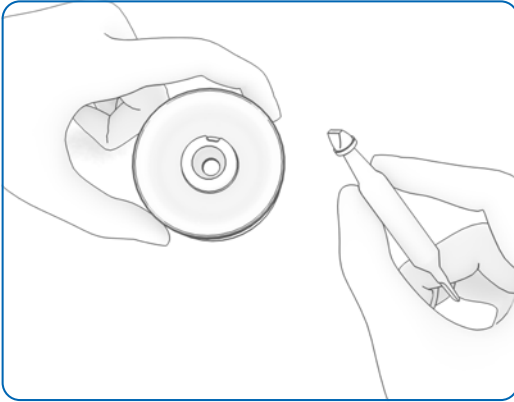
**Figure 24: Check valve removal with tool—part 1**



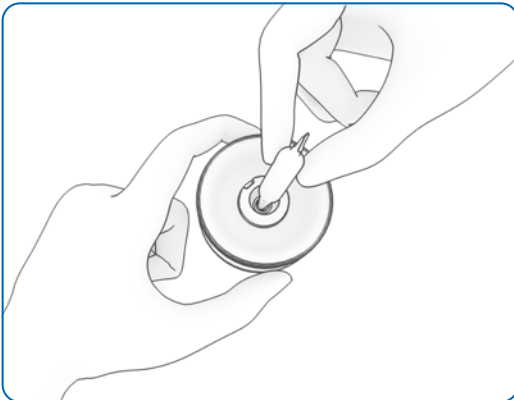
**Figure 25: Check valve removal with tool—part 2**

- Remove the internal gasket using the gasket removal tool
- Clean the stainless-steel pump head carefully including the grooves using a wipe moistened with a surface sanitizer listed in the cleaning & maintenance section

- Clean the gaskets and the check valve carefully using a wipe moistened with the sanitizer
- Put the gaskets and check valve back in place using the gasket removal tool



**Figure 26: Check valve installation with tool—part 1**

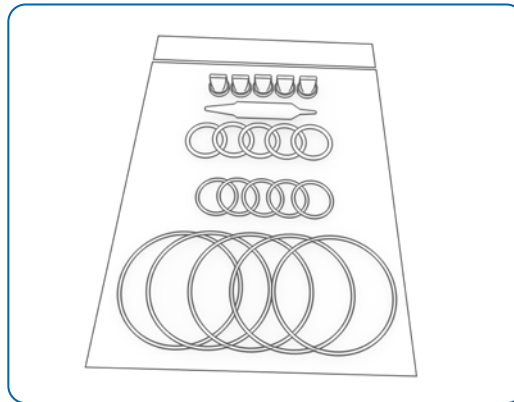


**Figure 27: Check valve installation with tool—part 2**

## 4.9 Filtration head gaskets and check valve (spare parts) replacement

Materials:

1. Pump head
2. Spare part kit to be found in the pump package or in the “filtration head for EZ-Fit® filtration unit gasket kit” item MMGASKTEZ



**Figure 28: Filtration head for EZ-Fit® filtration unit gasket kit, item MMGASKTEZ**

- Remove the filtration head
- Remove the gaskets and the check valve and discard them (details in previous chapter)
- Take out a set of gaskets and one (black) check valve out of the gasket kit bag and clean them using a wipe moistened with a sanitizer
- Put the new gaskets and the check valve in place using the gasket removal tool (details in previous chapter)

## 4.10 Sanitization kit gaskets (spare parts) replacement

### Materials:

1. Sanitization kit (item MMSANKIT1)
2. Sanitization kit gasket kit (item MMGASKTSK) containing:
  - Five O-rings for securing funnel to kit tightness
  - Five O-rings for securing kit to pump tightness
- Remove the gaskets (using the metal tool provided with the gasket kit) from the sanitization kit and discard them
- Take out a set of gaskets out of the gasket kit bag and clean them using a wipe moistened with a surface sanitizer listed in the cleaning & maintenance section
- Put the new gaskets in place



## 5. Performance verification

The accuracy of the vacuum level provided by the pump can be easily checked at any time, however this verification is not mandatory.

Materials:

1. Sanitization kit (item MMSANKIT1)
  2. Consumables for sanitization kit (item MMSANSYFU)
  3. Milliflex Oasis® vacuum gauge for pump verification testing (item MMSANSYFU)
    - This item is provided in the sanitization kit or can be purchased separately (it comes with a certificate of calibration).
  4. Stopwatch
  5. Purified water
- Remove the pump heads
  - Place the sanitization kit and lock it on the pump head support Lock the sanitization kit plug on the other support
  - Rotate the trigger clockwise, the switch turns white
  - Place a sanitization funnel assembly (sanitization kit consumables) on the sanitization kit
  - Connect the Milliflex Oasis® vacuum gauge to the syringe port of the kit

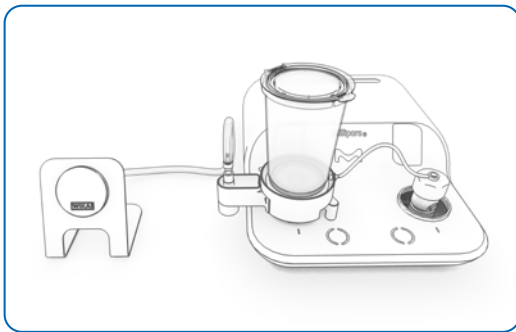


Figure 29: Set up for performance verification

Internal flow prewetting step:

1. Pour purified water up to the 250 mL indication level
2. Touch the switch to start the filtration
3. Stop the filtration when it is complete
4. Disconnect the vacuum gauge to reset it and connect it back to the syringe port of the kit

Verification of the vacuum level and verification of the flow time:

5. Pour again purified water in the funnel up to the 250 mL indication level
6. Start the stop watch and at the same time the filtration by touching the switch
7. Record the vacuum level on the gauge and the time needed to complete the filtration
8. Stop the filtration when there is no more water
9. Disconnect the vacuum gauge to reset it and connect it back to the syringe port of the kit
10. Repeat steps 4 to 9 twice more

Check that the average values are within the following specifications.

Pressure	Filtration time
< -0.4 bars	≤ 25 seconds for 250 mL water

- Remove the sanitization kit and clean it using a wipe moistened with a surface sanitizer listed in the cleaning & maintenance section

## 6. Use of multiple pumps

Up to three pumps can be connected providing the following benefits:

- Higher throughput
- Use of single power supply
- Daisy chain start: up to six samples filtered with a single push of a button

### 6.1 Material needed

#### 6.1.1 Two pumps connected:

- Two Milliflex Oasis® pumps for EZ-Fit® filtration unit (item MMSYSTEZ1)
- Milliflex Oasis® electrical cable for connecting two pumps (item MMCABLEMM)
- Milliflex Oasis® power supply, the item number is specific to defined regions:
  - Australia: item MMPWRSPAU
  - Brazil: item MMPWRSPBR
  - China: item MMPWRSPCN
  - Denmark: item MMPWRSPDK
  - Europe: item MMPWRSP EU
  - Switzerland: item MMPWRSPSZ
  - India: item MMPWRSPIN
  - UK: item MMPWRSPUK
  - Japan: item MMPWRSPJP
  - USA: item MMPWRSPUS
  - South Africa: item MMPWRSPZA

Optional: Milliflex Oasis® T connectors for tubing (item MMTCONNECT)

#### 6.1.2 Three pumps connected:

- Three Milliflex Oasis® pumps for EZ-Fit® filtration unit (item MMSYSTEZ1)
- Two Milliflex Oasis® electrical cables for connecting two pumps (item MMCABLEMM)
- Milliflex Oasis® power supply, the item number is specific to defined regions

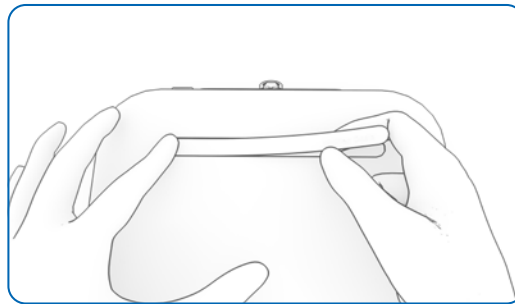
Optional: Milliflex Oasis® T connectors for tubing (item MMTCONNECT)

### 6.2 Installation

The pumps must be installed on a level surface to ensure good sample volume readings.

- Take the pump bodies and the tubing out of the package with care
- Take out the accessory bags

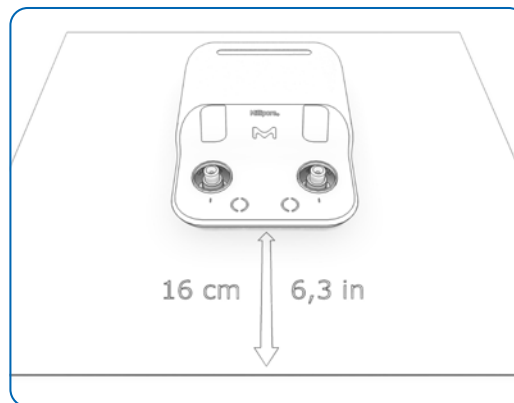
Optional: the accessory bag contains four stickers, select your preferred sticker and stick it carefully to the specific groove on each pump.



**Figure 30: Pump sticker set up**

- Clean the exterior of the pumps and the tubing using a wipe moistened with a surface sanitizer listed in the cleaning & maintenance section
- Place the pumps in the working area

Under a horizontal laminar flow hood, the front of the pumps must be placed at least at 160 mm (6.3 in.) from the front edge of the LFH (see picture).



**Figure 31: The front of the pump must be placed at least at 160 mm (6.3 in.) from the front edge of a horizontal LFH**

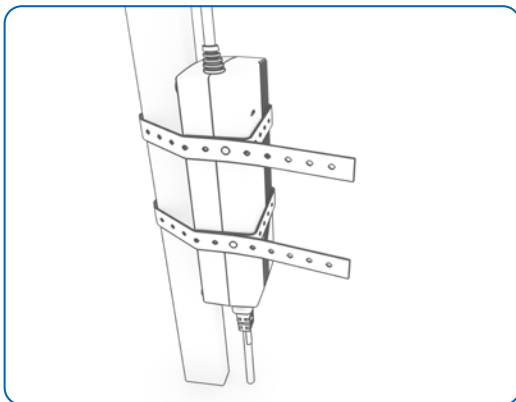
- At the back each pump, press the metal latch and remove the white plug, then connect the tubing
- Place the other end of the tubing in a liquid waste container

Optional: to save space, it is possible to connect the tubing together using the Milliflex Oasis® T connectors (item MMTCONNECT). In this case cut the tubing to the desired length and connect them.

- Take out the power supply out of its package
- Clean the power supply as described previously
- Use the Milliflex Oasis® electrical cable for connecting two pumps (item MMCABLEMM) to connect one power port of pump A to one power port of pump B. Repeat for the third pump if applicable
- Push the connectors into the power ports until a click is heard
- Plug the DC power cord in the free power port, at the back of the Milliflex Oasis® pump A
- Plug the region-specific power cord to the appropriate electrical power source; the Milliflex Oasis® pumps power-up: all the touch switches light up

Optional: to arrange the tubing and the electrical cable in your working area, it is possible to use the Milliflex Oasis® guides for electrical cable and tubing (item MMTUGUIDE)

Optional: attach the power supply outside the working area with the two rubber fasteners



**Figure 32: The power supply can be attached outside the working area with the rubber fasteners**

- For each pump, remove the two pump heads from their package and remove the yellow covers

Optional: From the accessory bags, select colored rings, clean them using a wipe and one of the sanitizers recommended in the cleaning & maintenance section, then install them on the pump heads.

- Clean the pump heads using a wipe moistened with a surface sanitizer listed in the cleaning & maintenance section
- Install the pump heads on the pump bodies
- Lock the pump heads by turning clockwise until the sign on the head is aligned with the one on the pump body



**Figure 33: The sign on a locked head is aligned with the one on the pump body**

- Sanitize the internal flow path of the pumps, please refer to the sanitization described in the cleaning & maintenance section

The pumps are ready for testing.

To start multiple filtrations simultaneously (daisy chain), touch the switch three times within one second. Please refer to the testing section of this manual for the other steps of the testing.

## 7. System specifications

### Milliflex Oasis® pump

Frame	Acrylonitrile Styrene Acrylate and Polycarbonate, compatible with standard UV sterilization
Filtration heads	Two per pump, stainless steel, silicone, rubber gaskets
	Can be autoclaved at 121 °C for 15 minutes or at 134 °C for 5 minutes

### Pump dimensions

Height	90 mm (3.5 in.)
Width	230 mm (9.0 in.)
Depth	310 mm (12.2 in.)
Filtration support height	75 mm (2.8 in.)
Weight with filtration heads	3.4 kg (7.5 lb)
Power supply	100V–240V 50/60Hz—One set can be used for up to three pumps

### EZ-Fit® Filtration Unit

#### Material of construction

Cover	Polystyrene
Funnel	Styrene butadiene copolymer (SBC)
Membrane	Mixed cellulose esters, PVDF
Support pad (blue units only)	Cellulose
Base	Acrylonitrile butadiene styrene
Plug (Bulk blue units only)	Low-density polyethylene

#### Dimensions

Height	100 mL: 66.5 mm (2.6 in.) 250 mL: 108.5 mm (4.3 in.)
Largest diameter	75.8 mm (3.0 in.)
Filtration surface	12.56 cm <sup>2</sup>
Sterilization method	EO for blue units, e-beam irradiation for pink units

### Milliflex Oasis® pump: materials in contact with the liquid filtered

Part	Material
Filtration head	Stainless steel ASI 316 L
	Silicone (gaskets & check valve)
Inner tubing	Low-density polyethylene (LDPE)
Tubing fittings	Polyphenylsulfone (PPSU)
	Polypropylene (PP)
	Acetal
	Buna N rubber
Core pump module	Polypropylene (PP)
	FKM (Viton®)
	PTFE (Teflon®)
Drain tubing	Silicone

## 8. Ordering information

Description	Qty/pack	Packaging/Format	Catalogue No.
<b>PINK base—no pad</b>			
EZ-Fit® Filtration Unit, white plain PVDF membrane, 0.45 µm, 100 mL	48	Single	EFHVV101S
EZ-Fit® Filtration Unit, white gridded MCE membrane, 0.45 µm, 100 mL	48	Multipack of 3 units	EFHAW10MS
EZ-Fit® Filtration Unit, white gridded MCE membrane, 0.45 µm, 250 mL	48	Bulk with protective bag	EFHAW25BS
EZ-Fit® Filtration Unit, black gridded MCE membrane, 0.45 µm, 100 mL	48	Multipack of 3 units	EFHAB10MS
EZ-Fit® Filtration Unit, black gridded MCE membrane, 0.45 µm, 250 mL	48	Bulk with protective bag	EFHAB25BS
EZ-Fit® Filtration Unit, white gridded MCE membrane, 0.22 µm, 100 mL	48	Multipack of 3 units	EFGSW10MS
EZ-Fit® Filtration Unit, white gridded MCE membrane, 0.22 µm, 100 mL	48	Single	EFGSW10IS
EZ-Fit® Filtration Unit, white gridded MCE membrane, 0.8 µm, 100 mL	48	Bulk with protective bag	EFAAW10BS
EZ-Fit® Filtration Unit, white gridded MCE membrane, 0.8 µm, 250 mL	48	Bulk with protective bag	EFAAW25BS
EZ-Fit® Filtration Unit, black gridded MCE membrane, 0.8 µm, 100 mL	48	Bulk with protective bag	EFAAB10BS
EZ-Fit® Filtration Unit, black gridded MCE membrane, 0.8 µm, 250 mL	48	Bulk with protective bag	EFAAB25BS
<b>BLUE base—with pad</b>			
EZ-Fit® Filtration Unit, white gridded MCE membrane, 0.45 µm, 100 mL	48	Bulk	EFHAW100B
EZ-Fit® Filtration Unit, white gridded MCE membrane, 0.45 µm, 100 mL	48	Single	EFHAW100I
EZ-Fit® Filtration Unit, white gridded MCE membrane, 0.45 µm, 250 mL	48	Bulk	EFHAW250B
EZ-Fit® Filtration Unit, white gridded MCE membrane, 0.45 µm, 250 mL	48	Single	EFHAW250I
EZ-Fit® Filtration Unit, black gridded MCE membrane, 0.45 µm, 100 mL	48	Bulk	EFHAB100B
EZ-Fit® Filtration Unit, black gridded MCE membrane, 0.45 µm, 100 mL	48	Single	EFHAB100I
EZ-Fit® Filtration Unit, black gridded MCE membrane, 0.45 µm, 250 mL	48	Bulk	EFHAB250B
EZ-Fit® Filtration Unit, black gridded MCE membrane, 0.45 µm, 250 mL	48	Single	EFHAB250I
<b>ISO Compliant Media</b>			
ReadyPlate™ 55 CCA ISO 9308	20	55 mm plates	1.46757.0020
ReadyPlate™ 55 CCA ISO 9308	200	55 mm plates	1.46757.0200
ReadyPlate™ 55 Lactose TTC ISO 9308	20	55 mm plates	1.46759.0020
ReadyPlate™ 55 Slanetz and Bartley ISO 7899	20	55 mm plates	1.46765.0020
ReadyPlate™ 55 CN Agar ISO 16266	20	55 mm plates	1.46767.0020

Hardware, accessories, spare parts and services		
Milliflex Oasis® filtration pump for EZ-Fit® filtration unit, one system with two filtration heads and no power supply	1	MMSYSTEZ1
Milliflex Oasis® filtration pump without filtration head and no power supply	1	MMSYSTVAC
Milliflex Oasis® power supply for one to three filtration pumps—Australia	1	MMPWRSPAU
Milliflex Oasis® power supply for one to three filtration pumps—Brazil	1	MMPWRSPBR
Milliflex Oasis® power supply for one to three filtration pumps—China	1	MMPWRSPCN
Milliflex Oasis® power supply for one to three filtration pumps—Denmark	1	MMPWRSPDK
Milliflex Oasis® power supply for one to three filtration pumps—Europe	1	MMPWRSP EU
Milliflex Oasis® power supply for one to three filtration pumps—India	1	MMPWRSPIN
Milliflex Oasis® power supply for one to three filtration pumps—Japan	1	MMPWRSPJP
Milliflex Oasis® power supply for one to three filtration pumps—Switzerland	1	MMPWRSPSZ
Milliflex Oasis® power supply for one to three filtration pumps—United Kingdom	1	MMPWRSPUK
Milliflex Oasis® power supply for one to three filtration pumps—United States	1	MMPWRSPUS
Milliflex Oasis® power supply for one to three filtration pumps—South Africa	1	MMPWRSPZA
Milliflex Oasis® filtration head for EZ-Fit® filtration unit	1	MMHEADEZ1
Gaskets replacement kit for Milliflex Oasis® filtration head for EZ-Fit® filtration unit, including gaskets removal tool	5	MMGASKTEZ
Milliflex Oasis® drain tubing	1	MMDRNTUBE
Milliflex Oasis® internal flow sanitization kit, including one vacuum gauge	1	MMSANKIT1
Milliflex Oasis® internal flow sanitization gasket kit	5	MMGASKTSK
Milliflex Oasis® consumables for internal flow sanitization kit	24	MMSANSYFU
Milliflex Oasis® vacuum gauge for pump performance testing	1	MMGAUGEMM
Milliflex Oasis® electrical cable for connecting two pumps	1	MMCABLEMM
Milliflex Oasis® T connectors for tubings for connecting two pumps	3	MMTCNNECT
Milliflex Oasis® guides for electrical cable and tubing	20	MMTUGUIDE
Stickers and filtration head rings for customizing the Milliflex Oasis® pump	4	MMCUSTKIT

## 9. Troubleshooting

Problem	Resolution
<b>Installation</b>	
Pump power supply is missing	The power supply is not comprised with the pump and has to be ordered separately. A list of 11 power supply items for specified regions is available.
Impossible to connect the tubing for discarding the liquids	Press the connector metal latch down prior to inserting the tubing.
The switch color is red after installing the pump head	The pump head is not locked properly. Remove the pump head, reinstall the pump head and press the switch.
<b>Material preparation &amp; testing</b>	
The pump switch is not active	Check that there is no liquid on the switch.
Small amount of liquid in the pump head after filtration	It is normal to observe a small amount of liquid in the pump heads, this does not impact the testing results.
Large amount of liquid in the pump head after filtration	Make sure that you do not add liquid in the funnel while filtering and while there is no liquid left in the funnel.
Funnel leakage	The maximal sample temp is 60 °C (140 °F).
Sample is foaming out of the funnel	Use a 250 mL funnel.
Long filtration time	Change or check the filtration head gaskets and if issue remains, run a pump performance testing—see section 4.1—Cleaning and maintenance.
<b>Sanitization</b>	
Impossible to install the kit	Remove the kit, place it back and turn clockwise, see section 4.7—Pump internal flow sanitization.
Leakage when pouring the sterile water	Remove the sanitization funnel and check the position of the funnel gasket.
Remaining liquid in the funnel or in the syringe	The test was uncomplete, ie due to a power issue during the process. Restart the sanitization from the start.

## 10. Operator & equipment safety instructions

Please refer to the Operator & Equipment instructions addendum on [SigmaAldrich.com](https://www.sigmaaldrich.com)

## 11. Technical Assistance

For more information visit [SigmaAldrich.com/techservice](https://www.sigmaaldrich.com/techservice)

