

Cole-Parmer®

HG-800 Geno/Grinder®

Tissue and Cell Lyser for Biological Applications

Operation Manual

For 115V/230V (04575-42) and (61031-68)



For Product Information

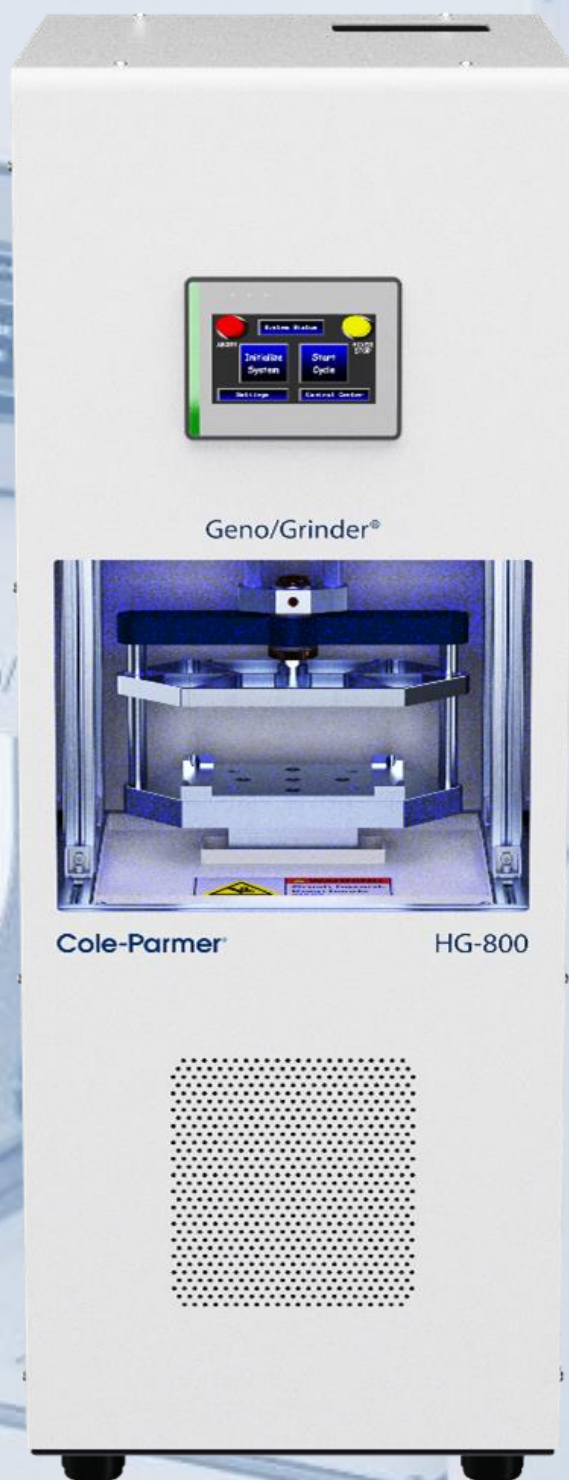

Cole-Parmer

1300-87057-1M, REV 3

HG-800

Copyright 2023 by Cole-Parmer

All rights reserved. No part of the work may be reproduced or transmitted in any form or by any means, electronic or mechanical; including photocopying and recording, except as may be expressly permitted by the 1976 Copyright Act or in writing from the publisher.

Requests for permission should be addressed in writing to Cole-Parmer, 65 Liberty Street, Metuchen, NJ 08840.

SPEX SamplePrep is now part of Cole-Parmer®.

The Cole-Parmer® HG-800 Geno/Grinder was formerly known as SPEX 2030 Geno/Grinder.

Over the years, we've acquired many high-quality and reputable brands. After many years of continual growth, we realize our brands are all as brilliant as each other. Rather than have a portfolio of complementary brands, we felt consolidating them under one world-class brand name enabled us to offer a single and significant brand experience. Through one brand we can speak in one voice through our team of experts who provide support in product selection, usage and troubleshooting to empower laboratories to run efficiently throughout the world.

Same Great Quality!

One World-Class Brand Name!

TABLE OF CONTENTS

SECTION	DESCRIPTION	PAGE
1.0	Introduction	4
2.0	Specifications	5
3.0	Unpacking	6
4.0	General Safety	8
5.0	Setting Up	9
5.1	Electrical Connection	9
6.0	Clamp Mechanism	10
6.1	Titer Plates	10
6.2	Releasing the Clamp	11
7.0	Operation	11
7.1	User-Interface Screen.....	11
7.2	Automation Software	16
7.3	Basic Protocol	17
7.4	Safety Recommendations	17
8.0	Error Messages	17
9.0	Maintenance	17
9.1	Safety Guidelines	18
9.2	Preventative Maintenance.....	18
9.3	Changing the Circuit Breakers	20
10.0	Accessories	20
11.0	Trouble-Shooting Guide	21
11.1	Unit does not power ON.....	21
11.2	Clamp Error Message.....	22
11.3	Mixer Home Error Message.....	22
11.4	Status Codes.....	22
12.0	Warranty	23
12.1	Product Specifications	23
12.2	To Arrange a Return Shipment.....	23
13.0	Instrument Disposal	24
14.0	Contact Us	25

1.0 INTRODUCTION

The HG-800 Geno/Grinder® was designed to effectively disrupt cellular materials by oscillating one or two deep-well titer plates vertically. Its vertical grinding motion effectively disrupts cellular materials by oscillating a single deep-well titer plate in 2 minutes or less. This motion allows the unit to be used to prepare sample tissue for extractions of nucleic acid, proteins, and other constituents by agitating the tissue, steel balls and a buffering agent together in each well of the titer plate.

The HG-800 Geno/Grinder was re-engineered as an automated unit that integrates with most robotic systems and platforms. A titer plate (or two titer plates with optional dual clamp) is placed into the HG-800 Geno/Grinder Clamp mechanism by a robotic arm. The computer interface is set up to Initialize and Start the Run Cycle (i.e. running time and stroke rate). When the run is complete, the robotic arm removes the titer plate and transfers it to the next stage in the automated platform. A new titer plate is placed in Clamp mechanism and the Run Cycle is repeated (Run times are typically less than two minutes).

Sample materials that can be prepared include seeds, stems, roots, leaves, and certain animal tissue. Because the unique vertical shaking motion of the HG-800 Geno/Grinder is so powerful, many seeds and other forms of plant tissue can be pulverized dry in titer plate with the aid of one or two grinding balls per well.

Features of the HG-800 Geno/Grinder include: stroke-rate settings between 500 and 1750 strokes per minute and run times adjustable from 15 seconds to 20 minutes. The clamp mechanism is automatically secured before the grinding process.

NOTE: THE HG-800 GENO/GRINDER IS INTENDED FOR USE ONLY BY QUALIFIED AND TRAINED PERSONNEL IN GENERAL AUTOMATION AND PROGRAMMING. DO NOT OPERATE THE HG-800 GENO/GRINDER UNTIL YOU HAVE READ THESE INSTRUCTIONS AND ARE FAMILIAR WITH ITS CONTROLS.

2.0 HG-800 GENO/GRINDER SPECIFICATIONS

Type of Grinder:	Automated, vertical impact grinder, designed for robotic systems and platforms.
Grinding Mechanism:	Grinding balls of stainless steel, silica or zirconium beads.
Dimensions	35.88 in. (91.1 cm) height x 12.88 in. (32.7 cm) width x 18.88 in. (48.0 cm) depth.
Weight:	125 lbs. (58 kg)
Capacity:	One standard well titer plate (e.g. 96 well), or two standard well titer plates with optional dual clamp. (sold separately)
Clamp Speed:	Adjustable range: 500-1750 strokes/min.
Clamp Travel:	1.25 in. (3.2 cm)
Electrical Specifications:	115V/60Hz or 230V/50Hz.
Circuit Breaker:	(3) Circuit Breaker Switches.
Cord:	115V/60Hz model: 3-prong grounded plug supplied. 230V/50Hz model: 2-prong European plug supplied. <i>NOTE: Operator is responsible for supplying alternate line cord/plug if required.</i>
Safety Features:	Clamp is automatically secured before the grinding process. On/Off button serves as additional circuit breaker.
CE:	CE approved for incorporation into automation system.
Motor:	3-phase servo motors.
Environment:	For indoor use only at a maximum altitude of 6600 ft. (2000 m). Operate at ambient conditions between 40°F (5°C) and 104°F (40°C), with maximum relative humidity 80% below 88°F (31°C) decreasing linearly to 50% at 104°F (40°C). Main supply voltage fluctuations up to 10% of nominal voltage (115 or 230 volts AC RMS). Pollution degree 1: none or only dry, conductive pollution occurs.

3.0 UNPACKING

Carefully inspect the exterior of the packing crate. Any visible damage should immediately be reported to the carrier. Remove all packing documents from the exterior of the crates and file in your records. Remove the top of the shipping crate, the foam packaging material, and the HG-800 Geno/Grinder. Lift the sleeve of the packing crate to remove from the base of the crate. Grasp the HG-800 Geno/Grinder on both sides, using proper lifting techniques, and place it on a stable bench top (This is a 2-person job). Visually check the units to ensure that no damage occurred during shipping. Inspect the accessories and compare with the Packing List to ensure that no parts are missing.

Follow a logical sequence of steps as you inspect the HG-800 Geno/Grinder.

1. Inspect the electrical/cable input for any visible damage.
2. Inspect the HG-800 Geno/Grinder cabinet for any visible damage.
3. Ensure that the switches and connectors are intact.
4. Inspect the interior of HG-800 Geno/Grinder.
- 5. Important!!! Remove the shipping clamp from Clamp Mechanism. (Figure 1)**
6. Check the Clamp Mechanism. Ensure that it is undamaged.
7. Check the packing list. Did you receive what you had ordered?

If everything appears to be in proper order, store the packaging materials in case there is a need to return the unit for service or repair.

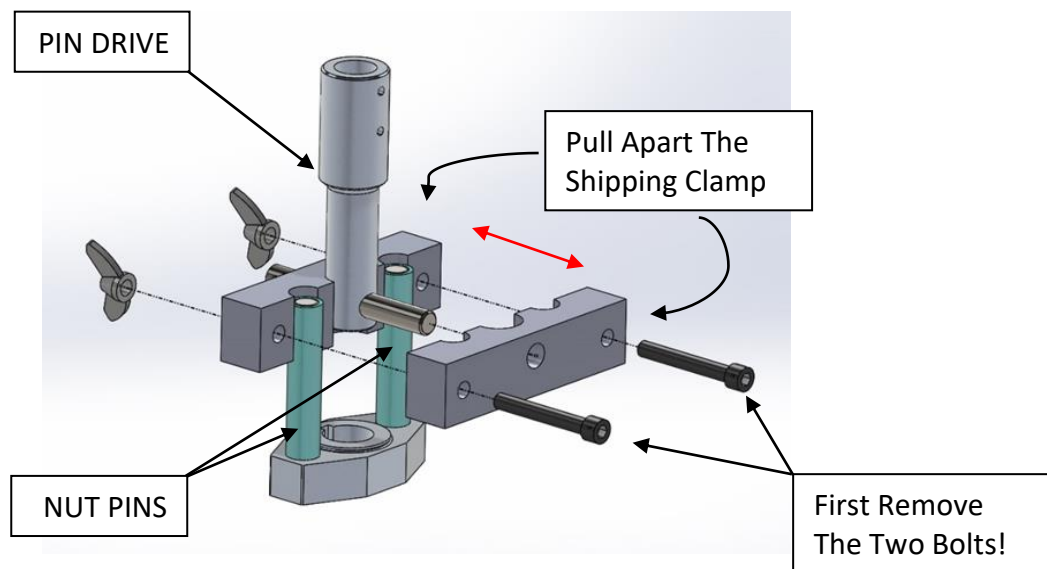

Figure 1 – Removal of Shipping Clamp

3.0 UNPACKING

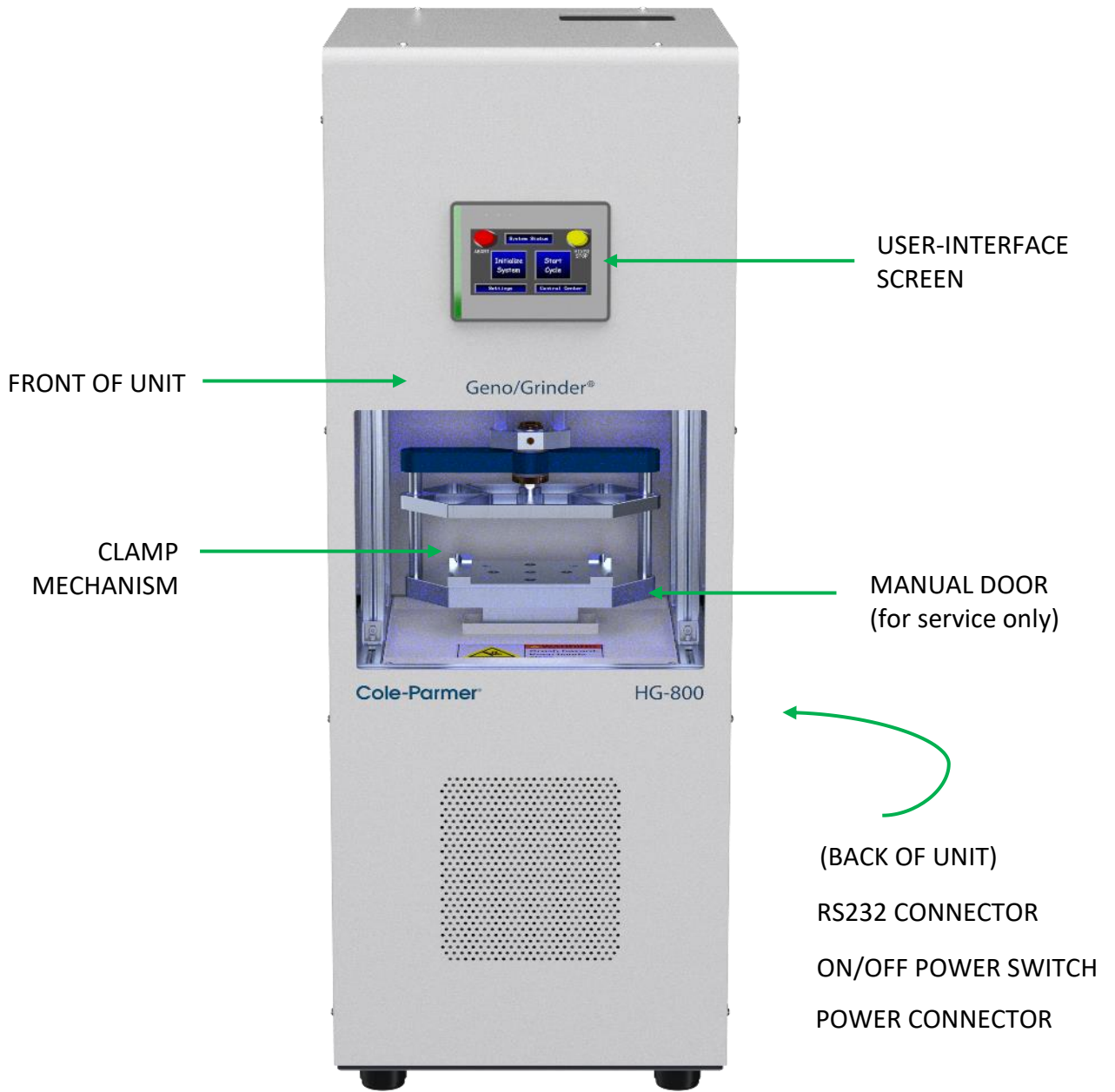

Figure 2 - HG-800 Geno/Grinder, Front View

4.0 GENERAL SAFETY

NOTE: To avoid injury, follow the safety information in this section. Keep these instructions for future reference.



WARNING

Caution: This warning symbol is visible in front of the HG-800 Geno/Grinder clamp mechanism. It is essential that hands are kept free from clamp area during operation and maintenance of unit.

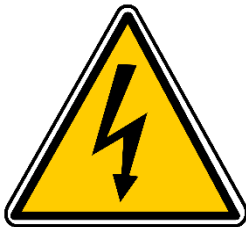

CAUTION

Caution: This warning symbol is visible on the back of the HG-800 Geno/Grinder. Turn OFF power to unit and disconnect the electrical cord before beginning any cleaning or maintenance of the unit.

Every effort has been made to ensure that the HG-800 Geno/Grinder is safe to operate. However, the safety protection provided by the unit may be impaired if the HG-800 Geno/Grinder is operated in a manner other than that described in this manual. It is necessary to position a protective shield around the robotic arm and platforms. The shielding must be provided by the installer to ensure adequate protection during operation. The protective shield does not need to be positioned around the HG-800 Geno/Grinder. The walls of the HG-800 Geno/Grinder serve as adequate shielding in all directions (except the front opening). In the event a damaged titer plate is ejected from the clamp its trajectory will be limited to the shielding around the robotic arm or platforms. The HG-800 Geno/Grinder should only be used with accessories provided by or recommended by Cole-Parmer and must be used in the intended manner. Use of accessories not recommended by Cole-Parmer may negatively affect the safety protection provided by the unit.

Do Not Use the HG-800 Geno/Grinder with hazardous materials for which the unit was not designed. Be aware of the hazards of the materials that are being used, particularly in the event of a spill. For instance, use of a flammable liquid could create a fire hazard if the sample is spilled.

Do Not Use the HG-800 Geno/Grinder with materials that are readily combustible. Combustible materials could release vapors creating a hazardous environment.

4.0 GENERAL SAFETY (Cont'd)

Do Not Use the HG-800 Geno/Grinder with materials that are inherently explosive. Certain materials (e.g. peroxides and peroxide-forming compounds) are shock sensitive.

Do Not Use HG-800 Geno/Grinder with materials that are known to be poisonous or known to release toxic fumes.

If hazardous materials must be handled in the HG-800 Geno/Grinder, including but not limited to, biological, microbiological, chemical, toxic, or infectious then a Risk Assessment should be conducted. The Risk Assessment will determine if additional safety measures (e.g. Bio-hood, fume hood, etc.) is needed.

5.0 SETTING UP

NOTE: Read all instructions before use to avoid injury.

5.1 Electrical Connection

The power (OFF/ON) switch and power cord receptacle is located on the rear of the unit (Figures 3). The detachable power cord should be plugged firmly into its inlet, then into an electrical outlet. Make sure that the electrical outlet is easily accessible in case it becomes necessary to unplug the unit. For 115V/60HZ use, a 3-prong outlet is recommended. The 230V/50HZ power cord has a standard European 2-prong plug, make sure the cord and plug conform to local electrical codes.

6.0 CLAMP MECHANISM

The clamp is the most critical component of the HG-800 Geno/Grinder, as it must securely hold the titer plate firmly in place. The up-and-down motion of the clamp is extremely vigorous (Figure 3). **Note, remove shipping clamp before running, as shown in Figure 1.**

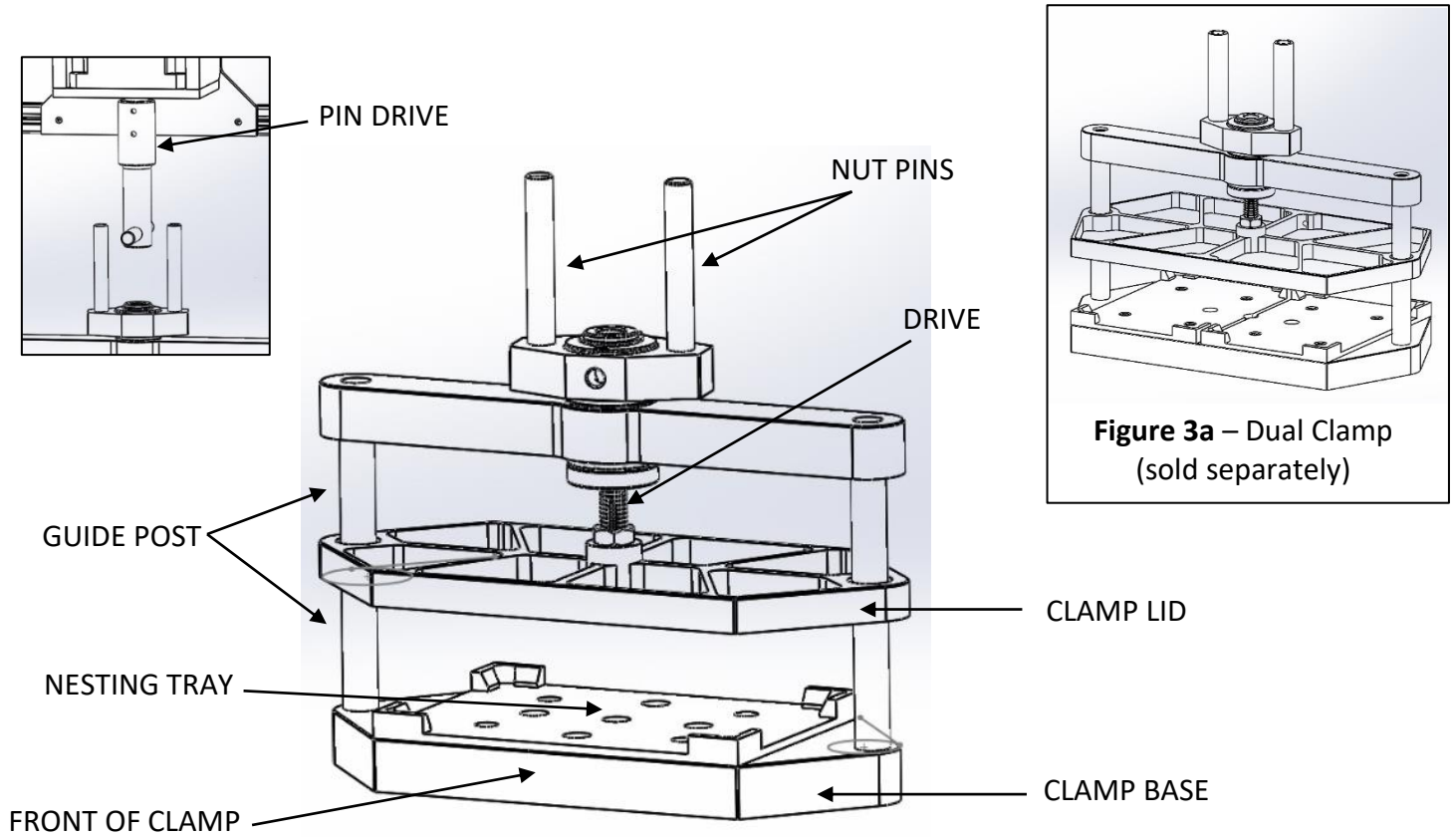

Figure 3 - HG-800 Geno/Grinder, Clamp Mechanism

6.1 Titer Plates

Titer plates are made by many companies and are sealed in various ways. The HG-800 Geno/Grinder is designed for use with the vast majority of currently available titer plates. Only one titer plate can be run with standard clamp in the HG-800 Geno/Grinder. Two titer plates can be run with optional dual clamp (sold separately) simultaneously. Plates can be sealed using a variety of formats. For PCR and DNA/RNA work a heat sealer is suggested, so as to minimize the possibility of contamination between wells.

While the precise details are left to the individual user, each well in the titer plate can be loaded with a seed, plant tissue, or other sample, and an eluent, solvent, etc. If it is necessary to disrupt the sample, a grinding element is added first, typically one to two 5/32" (4 mm) steel balls.

NOTE: Because the action of the HG-800 Geno/Grinder is so energetic and efficient, run times are short, typically from 30 seconds to 2 minutes. When developing a procedure, always start with a short running time and increase running times as needed.

6.2 Releasing the Clamp

NOTE: The User must teach the robotic arm the storage locations of the titer plates (Hotel) and the location of the titer plate in the HG-800 Geno/Grinder Clamp Mechanism. To reduce hazards (or potential injuries), it is necessary to install an external guard or shield (physical barrier) positioned around the robotic arm and platforms. The external guarding or shielding does not need to extend around the HG-800 Geno/Grinder. The walls of the HG-800 Geno/Grinder provide adequate shielding in all directions (except the front opening). In the event a damaged titer plate is ejected from the clamp its trajectory will be limited to the shielding around the robotic arm and platforms.

1. When the HG-800 Geno/Grinder comes to a complete stop, the titer plate is automatically released by the Clamp Lid.
2. The titer plate is then removed from the unit by robotic arm and placed in the Hotel or the next step in the automated process.
3. A new titer plate is picked up by the robotic arm and placed in the HG-800 Geno/Grinder Clamp Mechanism (Nesting Tray). (Figure 3)

7.0 OPERATION

7.1 User-Interface Screen

NOTE: The User-Interface Screen is designed for service of the HG-800 Geno/Grinder only. System checks and/or repairs should only be performed by qualified and trained personnel. The Manual Door must be closed for unit to operate in Service mode. To close Manual Door grasp knob and lift up to release door from the grooved lock-catch.

The Control Panel is located on the front of the HG-800 Geno/Grinder. Apply power to the system via the main circuit breaker located inside the unit. After a brief Self-Test, the unit will sound with a beep and the Main Control Screen will appear, as shown below in Figure 4. The system is controlled from this screen for service and maintenance. Close Manual Door.

When the unit is turned ON, the operating system is automatically in Host mode. Host mode can only be interfaced with an external computer. Only the Control Center, System Status, Abort, and Mixer Stop buttons are active in Host mode. To activate all buttons for Service mode press the Control Center button. Next press the Mode Select button in Control Center Screen (Figure 5) and change Host mode to Service mode (Figure 5).

7.1 User-Interface Screen (Cont'd)

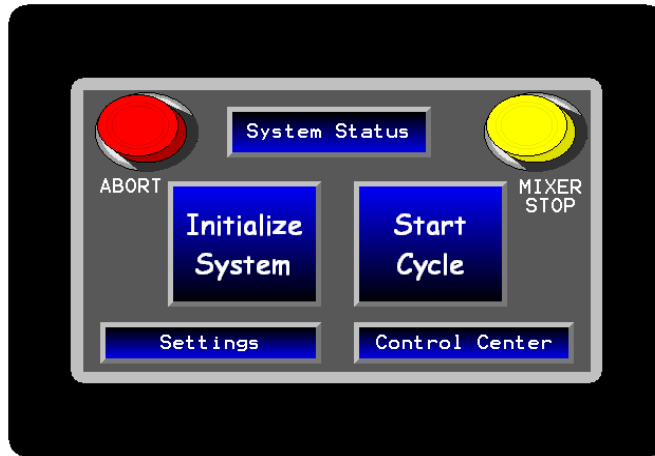

Figure 4 - Main Control Screen

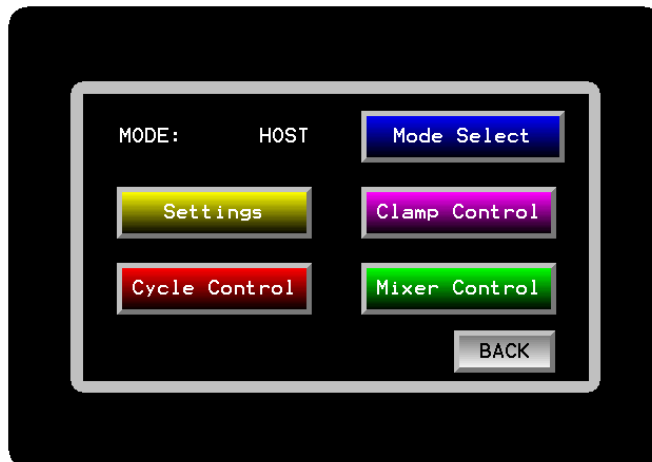

Figure 5 - Control Center Screen

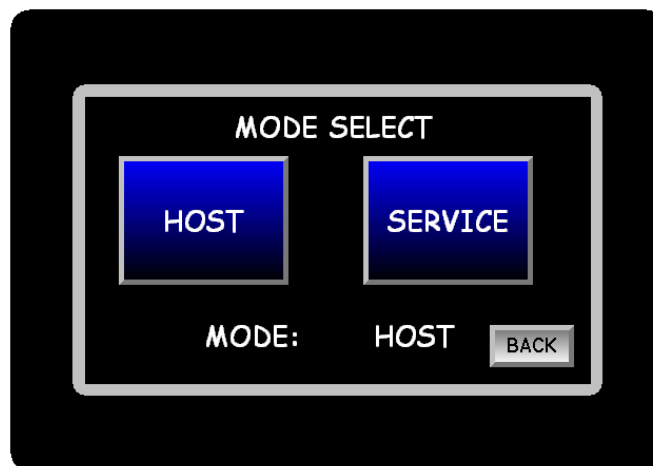

Figure 6 – Mode Select Screen

7.1 User-Interface Screen (Cont'd)

NOTE: Pressing the BACK button displayed on any of the user-interface screens returns to previous screen.

Press the BACK button to return to Control Center Screen, then press Back button again to return to Main Control Screen (Figure 4). Now press INITIALIZE SYSTEM button. The Clamp Mechanism will move to its home position. The PIN Drive will then engage the Nut Pins (the clamp should be open at this point). If the clamp is not open the unit will open the clamp. After opening the clamp the Pin Drive will stop then turn ¼ in the opposite direction to back Pin Drive off Nut Pins. The system will verify the clamp is open and the unit will sound with a beep acknowledging the Initialize System step is completed.

Pressing START CYCLE button will initiate the run sequence. To force the system to end while the clamp is in motion press MIXER STOP button or ABORT button (all motion will stop immediately). (Figure 4)

Setting Run Parameters: Press Settings button from the Main Control Screen to view Settings Screen, as shown in Figure 7. Pressing the parameter name (Process Rate or Processing Time) will activate a keypad pop-up.

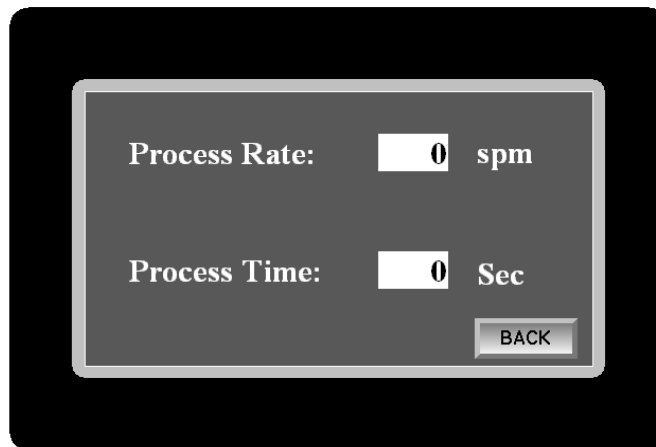

Figure 7 – Settings Screen

Type desired value followed by ENTER. Run Parameters values are stored in permanent memory. Press BACK button to return to Main Control Screen. Press Control Center button to view Control Center Screen (Figure 5). Press Clamp Control button to view Clamp Control Screen. (Figure 8)

To close clamp mechanism press CLOSE CLAMP button. To open clamp mechanism press OPEN CLAMP button.

7.1 User-Interface Screen (Cont'd)

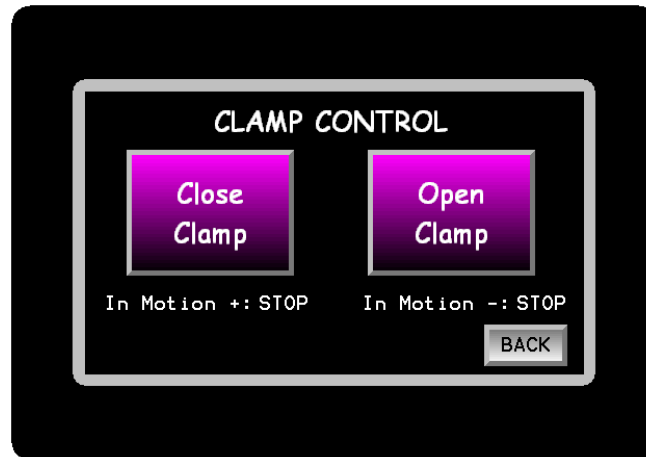

Figure 8 - Clamp Control Screen

Press BACK button to return to Main Control Screen (Figure 4). Press Control Center button to view Control Center Screen. Press Mixer Control button to view Mixer Control Screen (Figure 9). To position the clamp mechanism to its home position press HOME MIXER button. The Clamp Home Position is the access point for the Robotic Arm to load and remove titer plate in the HG-800 Geno/Grinder.



Figure 9 – Mixer Control Screen

Press BACK button to return to Control Center Screen. Press Cycle Control button to view Continuous Cycle Screen, as shown in Figure 10. To run the parameters from the SETTINGS SCREEN (Figure 7) press the START button. The PIN Drive will then engage the NUT PINS to open the Clamp. After opening the clamp the Pin Drive will stop then turn $\frac{1}{4}$ in the opposite direction to back Pin Drive off Nut Pins. After the Clamp opens the unit will beep and pause for a few seconds. The PIN Drive will then engage the NUT PINS to close the Clamp. After closing the Clamp the Pin Drive will pause then further tighten $\frac{1}{2}$ turn. The Pin Drive will

7.1 User-Interface Screen (Cont'd)

then turn ¼ in the opposite direction to back Pin Drive off Nut Pins. The unit will run for the specified time then stop. This cycle will continue until the STOP button is pressed.

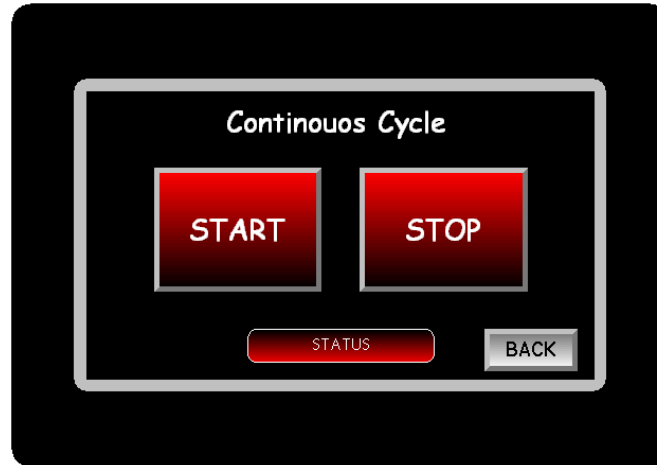

Figure 10 – Continuous Cycle Screen

To view the System Status, as shown in Figure 11, stop the continuous cycle then press the Status button. (Note: the System Status can also be accessed from the Main Control Screen (Figure 4). The system status displays the unit information such as Status; OK, Faulted or Error, Mode, total Elapsed Time, and Process data. (Refer to Troubleshooting Section 11.0) The Reset button sets the Elapsed Time to "0"hrs. Press the BACK button to return to the Continuous Cycle Screen.



Figure 11 - Status Screen

7.2 Automation Software

NOTE: This section covers the Demonstration Software supplied by COLE-PARMER SamplePrep. The Manual Door must be in the open position when running in automation mode.

Apply Power to the system via the main circuit breaker located inside the unit. After a brief Self-Test, the main control on the User-Interface screen will appear. Start the Demo Program.

Select FILE --- Select COM Port --- COM#. COM# is the Port that the computer assigns to the USB to RS232 Converter Cable.

Select INITIALIZE button (the only option available). The clamp will move to their home position. Finally the Pin Drive will engage the clamp (the clamp should be open at this point). If the clamp is not open then the unit will open the clamp. After the system verifies the clamp is open the unit will sound with a beep acknowledging the Initialize System step is completed.

NOTE: The system must be initialized each time the power is cycled.

After the system has initialized, the START and SETUP buttons will become active. Note: The Run Parameters must be set before the first run or the software's default values will over-write the system values.

Selecting START initiates a Run Cycle. During the Run, only the STOP option is available. After the run completes the START and SETUP options will become active again.

Selecting STOP while the clamp is in motion will force the system to end the run. Selecting STOP has no effect while the PIN Drive are in motion.

NOTE: An ABORT operation must be initiated via the User-Interface. Pressing ABORT will stop all motion immediately. The system must be reset after an abort action (turn OFF then turn ON).

7.2.1 Basic Command Set

Acknowledge	*01*	
Set Parameters	*02,ttt,rrrr*	t: 3 digit TIME (in seconds), r: 4 digit RATE (in rpm)
Initialize	*03*	
Start	*04*	
Unused	*05*	
Stop	*06*	
Abort	*08*	

NOTE: Each command is acknowledged by the controller by echoing back the command.

7.3 Basic Protocol

Commands and Status are sent as an ASCII string.

The asterisks (*_*) are required.

For the SET PARAMETERS command the commas are required, as are the leading zeros for TIME and RATE.

7.4 Safety Recommendations

If hazardous materials must be handled in the HG-800 Geno/Grinder, including but not limited to biological, microbiological, chemical, toxic, or infectious, then a Risk Assessment should be conducted. The Risk Assessment will determine if additional safety measures (e.g. bio- hood, fume hood, etc.) are needed.

To reduce hazards (or potential injuries), it is necessary to install an external guard or shield (physical barrier) positioned around the robotic arm and platforms. The external guarding or shielding does not need to extend around the HG-800 Geno/Grinder. The walls of the HG-800 Geno/Grinder provide adequate shielding in all directions (except the front opening). In the event a damaged titer plate is ejected from the clamp its trajectory will be limited by the shielding around the robotic arm and platforms.

8.0 ERROR MESSAGES

NOTE: If the following error message occur during operation please refer to the Trouble-Shooting Section 11.0 in this Manual.

- Clamp Error
- Mixer Home Error

9.0 MAINTENANCE

The HG-800 Geno/Grinder has been designed to provide trouble-free operation over a long period of time. To assure proper performance, the most important factor is cleanliness. There is a raised “dam” around the clamp shaft to keep spilled liquid from dripping onto the motor or drive mechanism; however, any spills should be cleaned up immediately.

The HG-800 Geno/Grinder cabinet is made primarily of painted steel and clear plastic. The interior as well as the exterior surfaces of the unit are designed to be easily cleaned in case of a sample spill. To maintain the overall appearance of the unit, occasionally wipe the exterior and interior of the HG-800 Geno/Grinder with a mild window cleaner or similar product (use a soft non-abrasive cotton cloth).

9.1 Safety Guidelines

NOTE: Turn OFF power to unit and disconnect the electrical cord before beginning any cleaning or maintenance of the unit.

9.2 Preventative Maintenance

NOTE: The first signs of wear is “NOISE”. System checks and/or repairs should only be performed by qualified and trained personnel.

Inspect the unit for wear and damage as follows:

- ✓ Every three months take the system offline and run the INITIALIZATION sequence (see Section 7.1 of this Manual). Take notice of any unusual noises or vibrations that may require further investigation.
- ✓ Every three months visually inspect HG-800 Geno/Grinder Clamp Mechanism, PIN Drive, and components are in good condition.
- ✓ Every three months inspect Fans and ensure that they are operational (Fans are located inside unit). Replace Fans if necessary and wire in the same manner as the original Fan was connected.
- ✓ Annually take the system offline; remove the side panels of HG-800 Geno/Grinder. Inspect the internal components for wear and loose hardware. (Figure 12)
 - Timing Belt; visually look over the belt for signs of wear and tear (free of frayed edges). Timing Belt should have good tension and fit snug on Pulley Assembly. Replace belt if necessary.
 - Ensure that all collars are tight on shaft. Springs and Leather Washers are in good condition. Replace if necessary.
 - Flywheel should fit firmly attached to drive shaft. Tighten or replace as necessary.
 - Motor Pulley and Drive Pulley should fit firmly attached to shafts with no side to side play or rocking.
 - Bearing Housing should fit firmly attached to plate.
 - Guide Plate should fit firmly attached to Ball Slide with no side to side play or rocking.
 - Ball Slide is intact and moves smoothly with no side to side play or rocking. Ball Slide should fit firmly attached to back plate.
 - Lubricate the Drive Nut with 1 drop of WD-40 to keep opening/closing clamp movement fluid in the two locations, as shown in Figure 13.

9.2 Preventative Maintenance (Cont'd)

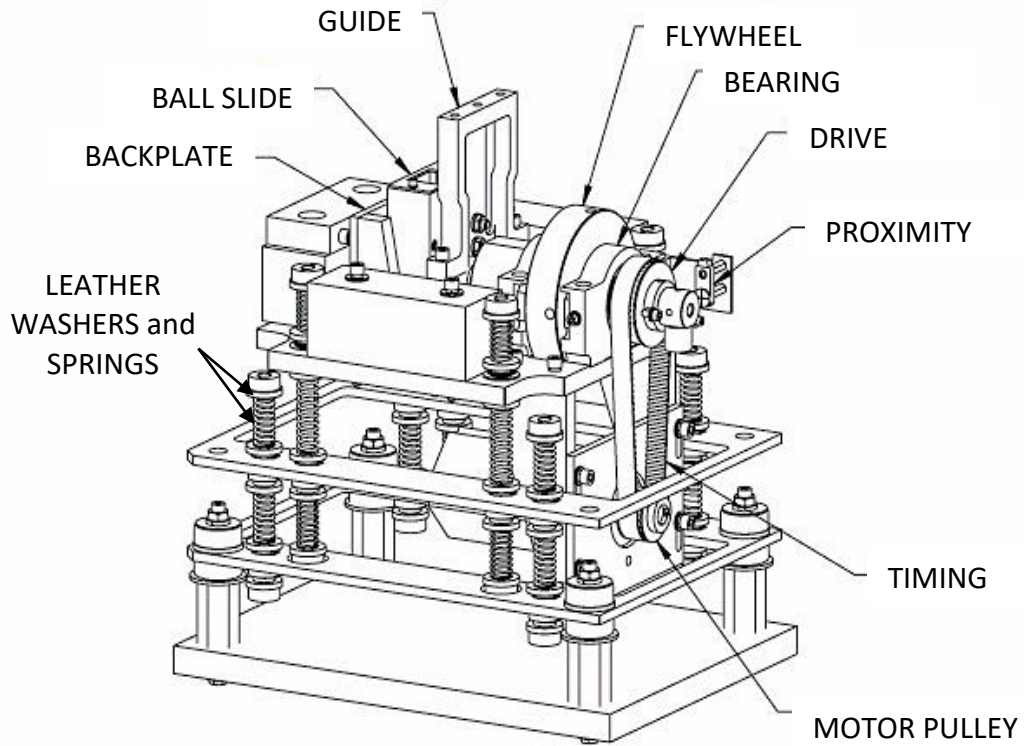

Figure 12 – Preventative Maintenance Diagram

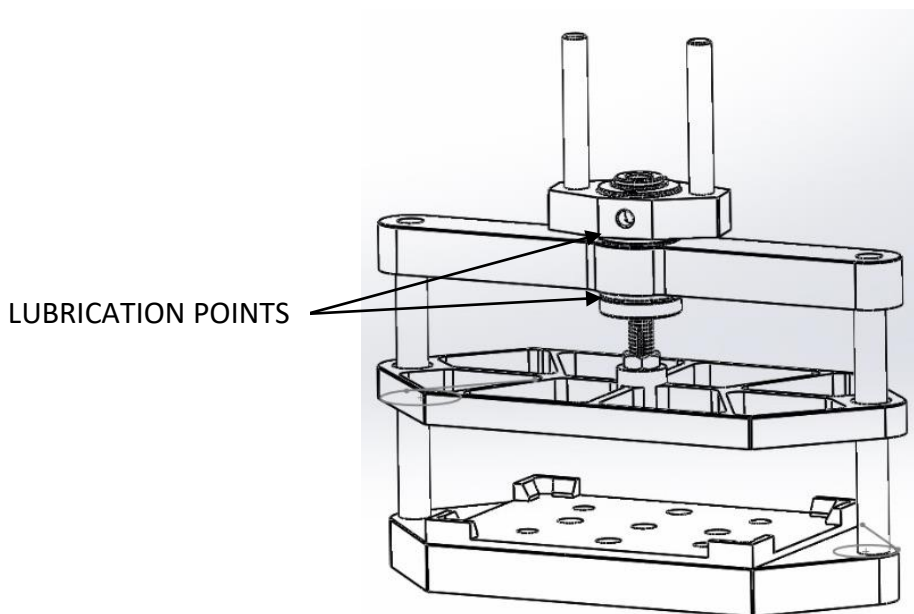

Figure 13 – Clamp Drive Nut

9.3 Checking the Circuit Breakers

If the HG-800 Geno/Grinder will not operate when the start button is pressed, it is possible that one of the three circuit breakers may have tripped. To access the circuit breakers, first remove the power cord from the back of the unit. Then remove the screws securing the back of housing for the unit. Check each circuit breaker, if any of the switches are in the OFF position, flip the switch to turn it back to the ON position. If the unit remains unresponsive when the start button is pressed, one of the circuit breaker may be defective. Another option is to test the circuit breakers using an Ohm-meter. To do this, first turn the breaker off, then remove it, turn it back on, and use the ohm-meter to check between its screws and bus clip. If there is a reading above 5 ohms, this means the circuit breaker is defective and must be replaced.

10.0 ACCESSORIES FOR THE HG-800 GENO/GRINDER

(Available for purchase at additional cost)

A partial list of available accessories is listed in this section. For a complete listing, please visit website Cole-Parmer.com.

2150 Grinding Balls 5/32 inch (4 mm)

Made of 440C stainless steel. Used with 2100 Grinding Ball Dispenser and all 96-well titer plates. Sold in bags of 5,000.

2100 Grinding Ball Dispenser

Simultaneously dispenses one 5/32 in. (4 mm) steel grinding ball (2150) into each well of a standard 96-well titer plate. (2200 and 2110 titer plates.)

Grinding Beads

Molecular Biology Grade Grinding Beads are treated to inactivate contaminating enzymes and have been tested accordingly. Low Binding Grinding Beads are coated to reduce non-specific binding of nucleic acids and proteins and are used for lysing dilute samples of cells. Acid Washed Grinding Beads are treated to remove fine particles and contaminants. They are suitable for most basic applications. Cole-Parmer offers all three grades in sizes ranging from 100 to 1000 µm.

See our website for a complete list at Cole-Parmer.com.

10.0 ACCESSORIES FOR THE HG-800 GENO/GRINDER (Cont'd)

Titer Plates and Cap-Mats

While most titer plates can be used in the HG-800 Geno/Grinder, these sturdy titer plates have been tested extensively with various samples, and resist perforation by steel grinding balls even at high clamp speeds. They can be used for many applications including sample libraries, mother-to-daughter automated plate pipetting, large sample dilutions and cell suspensions. Suitable for RNA extraction when used with 2600 Cryo-Station. Titer plates are made of polypropylene, with alphanumeric marks for well identification. Sold as one or in cases of 100. Cap-Mats seal titer plate wells, preventing spills and well-to-well contamination. Rugged silicone rubber, may be sterilized and re-used. Sold as one or in cases of 10.

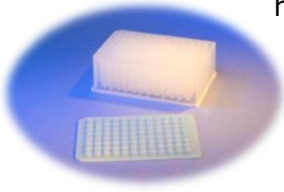

2200-100 96-Well Titer Plate, Square Wells, Case of 100

Square 2.4 ml wells with a working capacity of 2.0 ml. Case of 100 titer plates.



2201-10 Cap-Mats for 2200 Titer Plates, Case of 10

Sealing mats for the 2200 Titer Plates, above. Case of 10 Cap-Mats.

2210-100 96-Well Titer Plate, Round Wells, Case of 100

Round 2.0 ml wells, rugged polypropylene, alphanumeric marks for well identification. For use with the 2650 Cryo-Block, which is inserted in gaps between wells to keep plates and samples chilled to preserve RNA for extraction.

2211-10 Cap-Mat for 2210 Titer Plate, Case of 10

Sealing mats for 2210 Titer Plates. Tough silicone rubber, prevents leaks and cross-well contamination. Can be sterilized and re-used. Sold in cases of 10 mats.

11.0 TROUBLE-SHOOTING GUIDE

NOTE: Turn OFF power to unit and disconnect the electrical cord before beginning performing any trouble shooting steps from this section.

11.1 HG-800 Geno/Grinder does not power ON

The HG-800 Geno/Grinder does not power ON. Check all connections are secure. Remove the screws securing the back panel. Check each circuit breaker. (Section 9.3) If unit remains powerless contact Cole-Parmer for assistance.

11.2 Clamp Error Message

Turn OFF power to unit and disconnect the electrical cord. Check cable to computer interface connection is secure. Remove the screws securing the back panel of unit. Check each circuit breaker. (Section 9.3)

Turn ON power to unit. Refer to Section 7.1 of this Manual: from the Control Center Screen (Figure 5) press Clamp Control button to access the Clamp Control Screen (Figure 8). Press Open Clamp button to open the Clamp Mechanism. If the operation is successfully performed then press Close Clamp button. If the operation is successfully performed then repeat these steps a few times to ensure the Clamp Mechanism is functional. If Clamp Mechanism is not functional turn OFF power to unit and contact Cole-Parmer for assistance.

11.3 Mixer Home Error Message

Turn OFF power to unit and disconnect the electrical cord. Check cable to computer interface connection is secure. Remove the screws securing the back panel of unit. Check each circuit breaker. (Section 9.3)

Remove the side panels of HG-800 Geno/Grinder. Inspect the internal components for wear and loose hardware, as shown in Figure 12.

Turn ON power to unit. Refer to Section 7.1 of this Manual: from the Control Center Screen (Figure 5) press Mixer Control button to access the Clamp Home Screen (Figure 9). Press Home Mixer button to move the Clamp Mechanism. If the operation is successfully performed then repeat this step a few times to ensure the Clamp Mechanism is functional. If Clamp Mechanism is not functional turn OFF power to unit and contact Cole-Parmer for assistance.

11.4 Status Codes

- Status Codes are numerical readings displayed on Status Screen (Figure 11) and only used by Service Technician.
- If Mixer Status reads “Faulted” contact Cole-Parmer for assistance.
- If Torquer Status reads “Faulted” contact Cole-Parmer for assistance.

12.0 WARRANTY

Cole-Parmer® guarantees its products against defects in materials or workmanship for three years from the date of original shipment. Repairs, replacements, or parts are guaranteed for 30 days or for the remaining original warranty period (whichever is greater) for the item that was repaired or replaced. Items not produced by Cole-Parmer® carry the manufacturer's warranty only.

The warranty excludes wear parts. These are parts that wear out through use and must be replaced periodically for proper operation. HG-800 Geno/Grinder wear parts include the timing belt and ball slide.

In the event that these or other parts require service, please contact Cole-Parmer to arrange a return shipment.

The customer pays return freight for warranty claims. If the warranty claim is valid, Cole-Parmer® will pay return freight to the customer. However, Cole-Parmer® reserves the right to judge whether a malfunction during the warranty period is due to defects in materials or workmanship, or to wear, negligence, or misuse.

12.1 Product Specifications

Every effort has been made to provide complete and accurate product operation and information in this manual. However, since specifications are subject to change without notice, changes may be made from time to time to improve the performance of the product.

12.2 To Arrange A Return Shipment

We want you to be satisfied with your purchase from Cole-Parmer®. Please bring any problem to our attention, but please DO NOT RETURN any item before contacting us for a Return Authorization Number and instructions. Unauthorized returns will be refused. The cost for all return transportation is the responsibility of the customer. Credit for returned merchandise will be issued only after goods have been received and inspected. Returned goods are subject to a 25% restocking charge.

13.0 INSTRUMENT DISPOSAL

In accordance to the EU Directive 2012/19/EU covering Waste Electrical and Electronic Equipment, all equipment with the disposal symbol must not be disposed of with general waste. (See Figure 14)

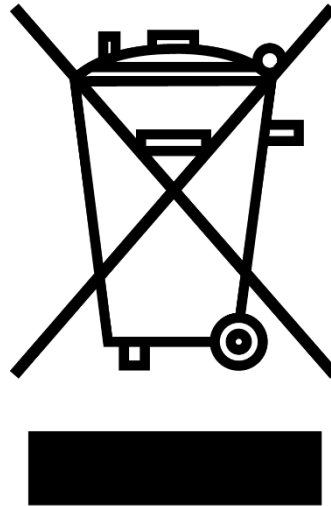

Disposal Label is located on the back of unit.

Figure 14 – Disposal Symbol

Throughout the European Community, guidelines regarding disposal regulations may vary from territory to territory. Please contact the national legislation or local authority for more information on proper disposal of all equipment with this symbol.

14.0 CONTACT US

Repair Service

Phone: 1.732.623.0465

Cole-Parmer
65 Liberty St
Metuchen, NJ 08840
US

Attn: Service and Repair

Please include RA Number on the shipping label.

Cole-Parmer®
an Antylia scientific company

625 East Bunker Ct.
Vernon Hills, IL 60061
US

US

T: +1.800.323.4340 or
+1.800.323.4340

E: sales@antylia.com

W: coleparmer.com

Canada

T: +1.514.355.6100

E: info@antylia.ca

W: coleparmer.ca

China

T: 86.21.5109.9909

E: sales@antylia.com

W: coleparmer.cn

France

T: +33 (0) 1486 37800

E: fr.sales@antylia.com

W: coleparmer.fr

Germany

T: +49 (0) 9377 92030

E: de.sales@antylia.com

W: coleparmer.de

India

T: +9122 61394444

E: info@coleparmer.in

W: coleparmer.in

Italy

T: +39 (0)2 84349215

E: it.sales@antylia.com

W: coleparmer.it

UK

T: +44 (0) 1480 272279

E: uk.sales@antylia.com

W: coleparmer.co.uk

Other

T: +1.847.549.7600